

Clock Oscillator VCXO7050TF3.3-6pad, 3.3V
Voltage Controlled Crystal Oscillator CMOS/TTL

- SMD in ceramic case (7.0 x 5.0 x 1.8) mm, on Tape & Reel (Tape 16mm)
- CMOS/TTL Output Wave Form
- SMD in ceramic case (7.0 x 5.0 x 1.8) mm, on Tape & Reel (Tape 16mm)
- with Tri-State Function, 3.3 V
- High Q fundamental crystal + ultra low jitter multiplier circuit
- RoHS conform; Lead-free product
- Vibration: MIL-STD-202F method 204, 35G, 50 to 2000 Hz
- Shock: MIL-STD-202F method 213B, test cond. E, 1000G 1/2 sine wave
- Available in many standard and special frequencies

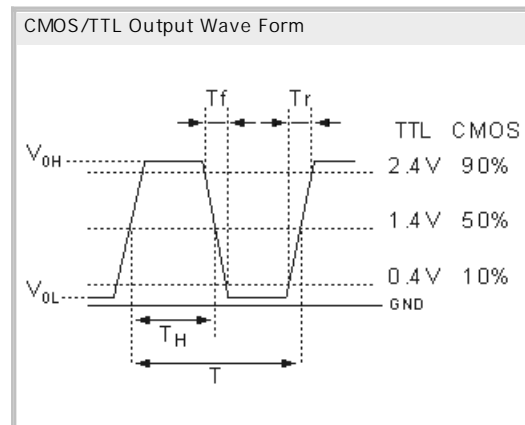
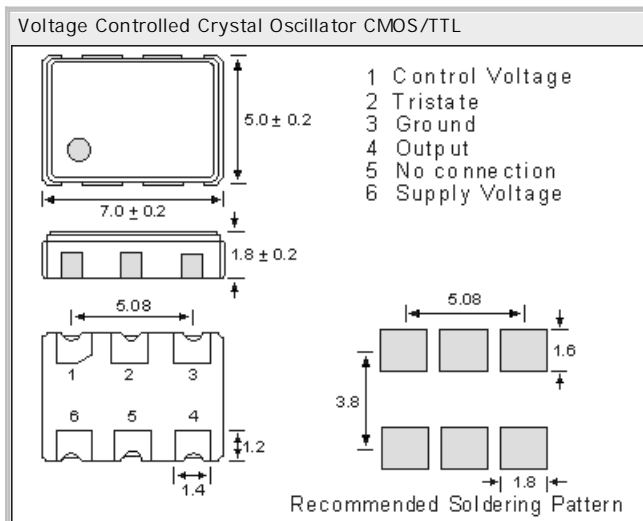

Specifications - Product No. G050000000CUSUPC00AB

Holder Type:	Voltage Controlled Crystal Oscillator CMOS/TTL VCXO7050TF3.3-6pad 3.3V(Voltage code is "3.3"); Tri-State
Frequency:	50.000000 MHz
Frequency Stability at 25°C:	± 25.0 ppm
Operating Temperature Range:	± 25.0 ppm over -20°C to +70°C (inclusive of 25°C tolerance, ± 10% input voltage variation, load change, aging, shock and vibration)
Frequency Deviation Range:	± 100.0 ppm
Storage Temperature:	-50°C to +100°C
Power Supply Voltage (Vdd):	+ 3.3V D.C. ± 5%
Maximum Supply Current (15pF load):	30.0 mA
Voltage Control:	1.65V DC Center / 0.3V to 3.0V Range
Load:	15pF
Output Logic Levels:	High "1" 90% of Vdd-min, Low "0" 10% Vdd-max.,
Output Symmetry (Duty Cycle):	50% ± 5% max. (measured at 50% Vdd)
Rise/Fall Time:	0.7ns typical, (0.3V<-> 3.0V, 15pF load)
Start Up Time:	10 ms (max.); 5 ms (typical)
Linearity:	6% typical, 10% max.
Tri-State Function:	Tri-State Enable High. No connection or 70% of Vdd min. is applied to a Tri-state pad to enable output. 30% of Vddmax. to disable outputs (high impedance).
Phase Jitter (12 kHz to 20 MHz):	0.4 ps typ., 0.5 ps max., for 156.250MHz
Phase Noise (typical), Vcon : GND:	(Offset 156.250 MHz) -62dBc/Hz @ 10Hz, -92dBc/Hz @ 100Hz, -120dBc/Hz @ 1kHz -132dBc/Hz @ 10kHz, -128dBc/Hz @ 100kHz, -140dBc/Hz @ 1MHz
Aging:	< ± 3ppm max. for the first year; 2ppm max. per year thereafter
Input Impedance:	60 K (min.)
Reflow Condition:	260°C max for 10 sec.

GERMANY:

COMTEC CRYSTALS GmbH · Sultenstrasse 12-14
8 5 5 8 6 P o i n g / G E R M A N Y
Phone +49 8121 778160 · Fax +49 8121 778177
e-Mail info@comtec-crystals.com
Internet: <http://www.comtec-crystals.com>
Subject to change without prior notice.



Technical Data and Graphics are all under
Copyright (c) of Comtec Crystals Group.

FRANCE:

COMTEC CRYSTALS SARL · 23, rue du Faucon
6 7 5 0 0 H a g u e n a u / F R A N C E
Phone +33 388 732162 · Fax +33 388 730118
e-Mail sales@comtec-crystals.com
Internet: <http://www.comtec-crystals.com>
Sous réserve de modifications.