

Crystal Unit UM1-SMD (HC52U-SMD)

- Quartz Crystal UM1-SMD (gull wing)
- on Tape & Reel

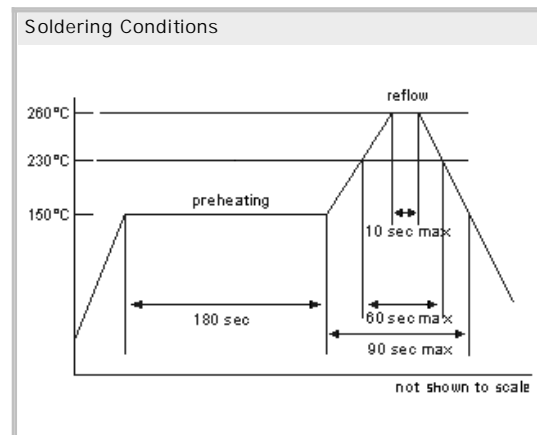
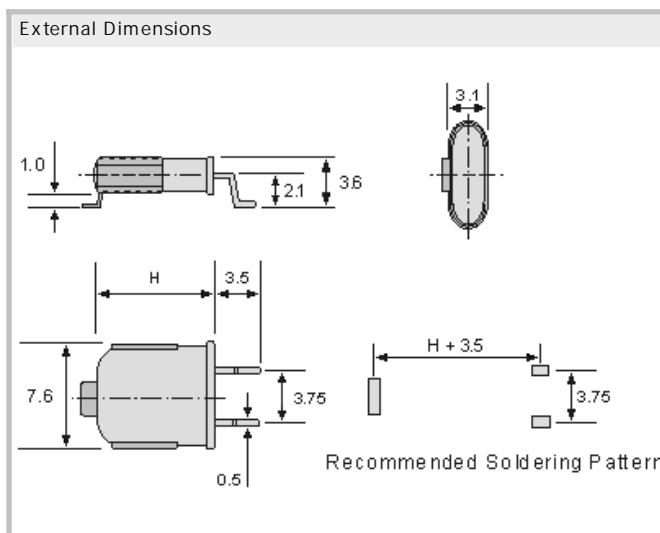

Specifications

Holder Type:	UM1-SMD / HC52U-SMD
Frequency Range:	1.000000 to 350.000000 MHz
Frequency Stability at 25°C:	± 30 ppm typ., ± 50 ppm max.
Temperature Stability:	± 30 ppm at -10°C to +70°C
Drive Level:	1.0 µW max.
Load Capacitance (CL):	12 to 50 pF, series (00)
Shunt Capacitance (CO):	7 pF max.
Vibration Mode:	AT-cut, F, 3rd, 5th, 7th, 9th overtone
Equivalent Series Resistance:	R = 25 to 250 Ohm max.
Aging:	± 5 ppm / year max.
Leak:	2 x 10 ⁻⁸ cc/sec max. helium

GERMANY:

COMTEC CRYSTALS GmbH · Sultenstrasse 12-14
 8 5 5 8 6 P o i n g / G E R M A N Y
 Phone +49 8121 778160 · Fax +49 8121 778177
 e-Mail info@comtec-crystals.com
 Internet: <http://www.comtec-crystals.com>
 Subject to change without prior notice.



Technical Data and Graphics are all under
 Copyright (c) of Comtec Crystals Group.

FRANCE:

COMTEC CRYSTALS SARL · 23, rue du Faucon
 6 7 5 0 0 H a g u e n a u / F R A N C E
 Phone +33 388 732162 · Fax +33 388 730118
 e-Mail sales@comtec-crystals.com
 Internet: <http://www.comtec-crystals.com>
 Sous réserve de modifications.