

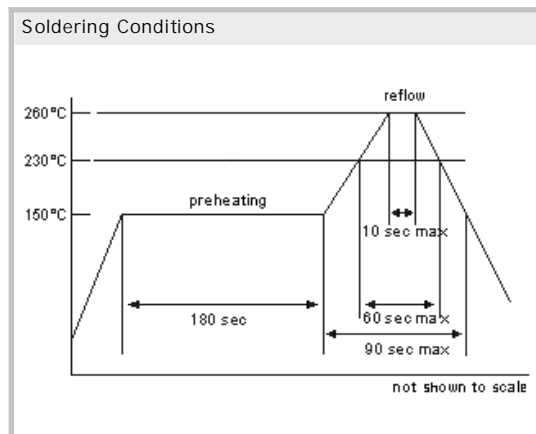

Quartz Crystal Unit HC49SMG (with ground)
h = 4.5mm

- Standard Quartz Crystal SMD with 3 pads
- Metal Case, EMI sensitive applications
- on Tape & Reel
- Available in many standard and special frequencies
- RoHS conform; Lead-free product

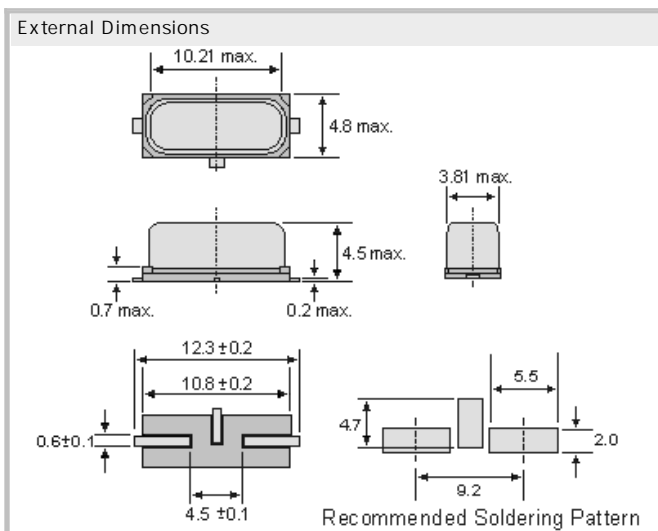

Specifications

Holder Type:	HC-49SMG with 3 pads (with ground)
Frequency Range:	3.000 to 70.000 MHz (fun.) 27.000 to 70.000 MHz (3rd)
Frequency Stability at 25°C:	± 10 to ± 50 ppm
Temperature Stability:	± 10 to ± 30 ppm @ -10°C to +60°C ± 10 to ± 30 ppm @ -20°C to +70°C ± 15 to ± 50 ppm @ -40°C to +85°C ± 50 to ± 100 ppm @ -40°C to +105°C
Storage Temperature:	-50°C to +105°C
Drive Level:	100µW (500µW max.)
Load Capacitance (CL):	8pF to 32pF, series (00)
Shunt Capacitance (CO):	< 7pF
Crystal Cut & Vibration Mode:	AT-cut, BT-cut, fundamental; - 3rd overtone
Equivalent Series Resistance:	R = 40 Ohm (fun.) - 150 Ohm max.
Aging:	< ± 3ppm max. / year (max.)

GERMANY:

COMTEC CRYSTALS GmbH · Sultenstrasse 12-14
8 5 5 8 6 P o i n g / G E R M A N Y
Phone +49 8121 778160 · Fax +49 8121 778177
e-Mail info@comtec-crystals.com
Internet: <http://www.comtec-crystals.com>
Subject to change without prior notice.



Technical Data and Graphics are all under
Copyright (c) of Comtec Crystals Group.

FRANCE:

COMTEC CRYSTALS SARL · 23, rue du Faucon
6 7 5 0 0 H a g u e n a u / F R A N C E
Phone +33 388 732162 · Fax +33 388 730118
e-Mail sales@comtec-crystals.com
Internet: <http://www.comtec-crystals.com>
sous réserve de modifications.